

Performance Table

Unit	Item	Model	J720ELIII					
			2300H		3100H		3900H	
Injection Unit	Screw cylinder type		A	B	A	B	A	B
	Screw diameter	in	3.31	3.62	3.62	3.94	3.94	4.33
	Screw stroke	in	16.536		18.111		19.685	
	Theoretical injection capacity	in ³	142.1	170.4	186.6	220.5	239.7	290.0
	Injection capacity (GP-PS)	oz	74.7	89.6	98.2	116.0	126.1	152.5
	Injection pressure (Max.)	psi	27500	22900	26800	22600	26800	22100
	Holding pressure (Max.)	psi	24800	20500	24200	20300	24200	20000
	Injection speed	in/sec	6.30		6.30		6.30	
	Injection rate	in ³ /sec	54.1	64.9	64.9	76.7	76.7	92.8
	Plasticizing rate (GP-PS)	oz/sec	3.63	4.61	4.61	5.68	4.90	6.07
	Screw speed	rpm	165		165		140	
	Nozzle touch force	US ton	6.6		6.6		6.6	
	Nozzle stroke from platen	in	2.0					
	Type of nozzle		Open nozzle					
	Cylinder temperature control		Cylinder 4 / Nozzle 1					
Heater wattage	kW	40.0		45.2		47.0		
Clamping Unit	Mechanism		Double toggle					
	Clamping force	US ton	717					
	Daylight opening (Max.)	in	78.742					
	Opening stroke (Max.)	in	39.37					
	Mold height	in	17.717 ~ 39.371					
	Distance between tie-bars (H×V)	in	41.7 × 37.8					
	Platen size (H×V)	in	59.1 × 55.1					
	Ejector type		25 points					
	Ejector force	US ton	19.9					
	Ejector stroke	in	7.874					
General	Machine weight	US ton	45.2		45.2		48.5	
	Machine dimensions (L×W×H)	ft	34.24 × 7.87 × 8.10		34.24 × 7.87 × 8.10		35.88 × 7.87 × 8.10	
	Hopper capacity	ft ³	4.4		6.0		6.0	

Remarks:

1. Injection pressure of J-ELIII series is different from that of JSW's hydraulic machines.
2. Maximum injection pressure and maximum holding pressure may be restricted due to molding condition.
3. The theoretical injection capacity is (cross sectional area of cylinder) × (stroke of screw) .
4. The injection capacity is applicable for GP-PS and variable according to the grade of resin, molding conditions and mold.
5. The plasticizing rate is applicable for GP-PS.
6. PC (polycarbonate) , HPVC, other engineering plastic, etc., low temperature setting and high speed molding may require a high torque depending on the grade or molding conditions. Please contact us if you plan.

Note:

1. Due to continual improvements, specifications are subject to change without notice.
2. Actual figures of the specification will vary depending on final machine configuration. Please contact us if you require more specific data.
3. Performance specifications are based on theoretical data.

Equipment Dimensions and Mold Related Dimensions

J720ELIII

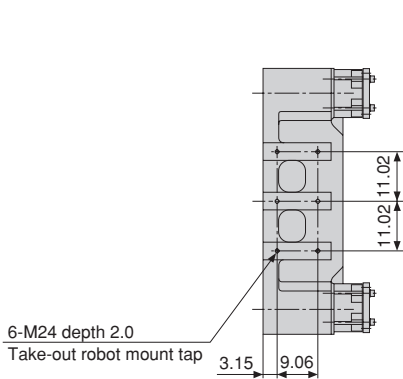
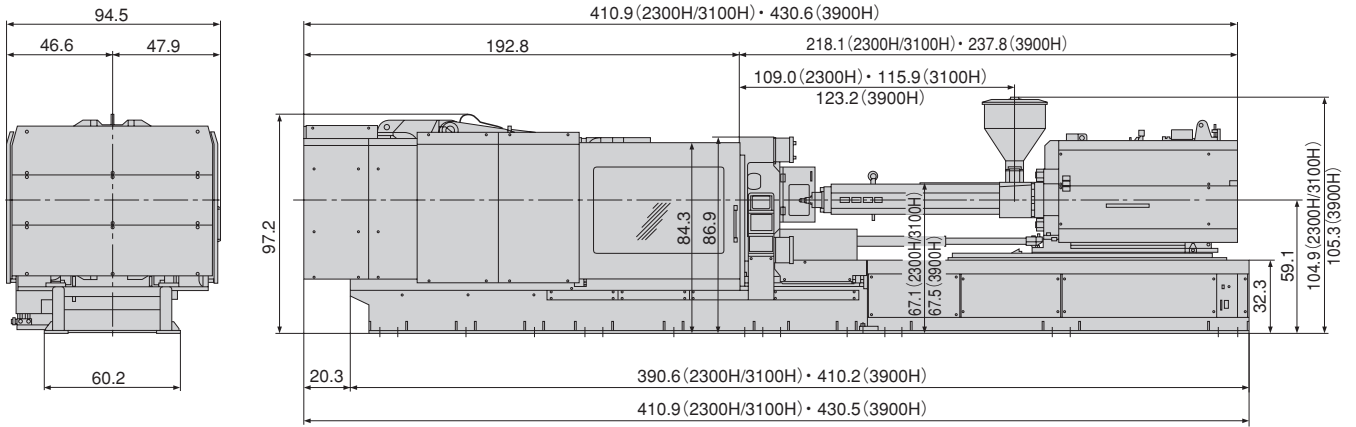

Upper surface of stationary platen

