

Performance Table

Unit	Item	Model	J1450ELIII					
			3900H		5200H		7800H	
Injection Unit	Screw cylinder type		A	B	A	B	A	B
	Screw diameter	in	3.94	4.33	4.33	4.72	4.33	4.72
	Screw stroke	in	19.685		21.654		32.481	
	Theoretical injection capacity	in ³	239.7	290.0	319.0	379.6	478.5	569.4
	Injection capacity (GP-PS)	oz	126.1	152.5	167.8	199.7	251.7	299.5
	Injection pressure (Max.)	psi	26800	22100	24900	20800	26100	21900
	Holding pressure (Max.)	psi	24200	20000	22400	18800	23400	19700
	Injection speed	in/sec	6.30		6.30		5.91	
	Injection rate	in ³ /sec	76.7	92.8	92.8	110.5	87.0	103.5
	Plasticizing rate (GP-PS)	oz/sec	4.90	6.07	5.68	7.05	5.59	6.47
	Screw speed	rpm	140		130		150	140
	Nozzle touch force	US ton	6.6		6.6		6.6	
	Nozzle stroke from platen	in	2.0					
	Type of nozzle		Open nozzle					
	Cylinder temperature control		Cylinder 4 / Nozzle 1				Cylinder 6 / Nozzle 2	
Heater wattage	kW	47.0		55.0		59.0		
Clamping Unit	Mechanism		Double toggle					
	Clamping force	US ton	1439					
	Daylight opening (Max.)	in	110.238					
	Opening stroke (Max.)	in	59.06					
	Mold height	in	25.591 ~ 51.182					
	Distance between tie-bars (H×V)	in	55.1 × 55.1					
	Platen size (H×V)	in	78.7 × 78.7					
	Ejector type		29 points					
	Ejector force	US ton	33.7					
	Ejector stroke	in	9.843					
General	Machine weight	US ton	98.1		98.1		100.3	
	Machine dimensions (L×W×H)	ft	42.73 × 10.07 × 10.10		43.37 × 10.07 × 10.10		46.47 × 10.07 × 10.10	
	Hopper capacity	ft ³	6.0		6.0		6.0	

Remarks:

1. Injection pressure of J-ELIII series is different from that of JSW's hydraulic machines.
2. Maximum injection pressure and maximum holding pressure may be restricted due to molding condition.
3. The theoretical injection capacity is (cross sectional area of cylinder) × (stroke of screw) .
4. The injection capacity is applicable for GP-PS and variable according to the grade of resin, molding conditions and mold.
5. The plasticizing rate is applicable for GP-PS.
6. PC (polycarbonate) , HPVC, other engineering plastic, etc., low temperature setting and high speed molding may require a high torque depending on the grade or molding conditions. Please contact us if you plan.

Note:

1. Due to continual improvements, specifications are subject to change without notice.
2. Actual figures of the specification will vary depending on final machine configuration. Please contact us if you require more specific data.
3. Performance specifications are based on theoretical data.

Equipment Dimensions and Mold Related Dimensions

J1450EL III

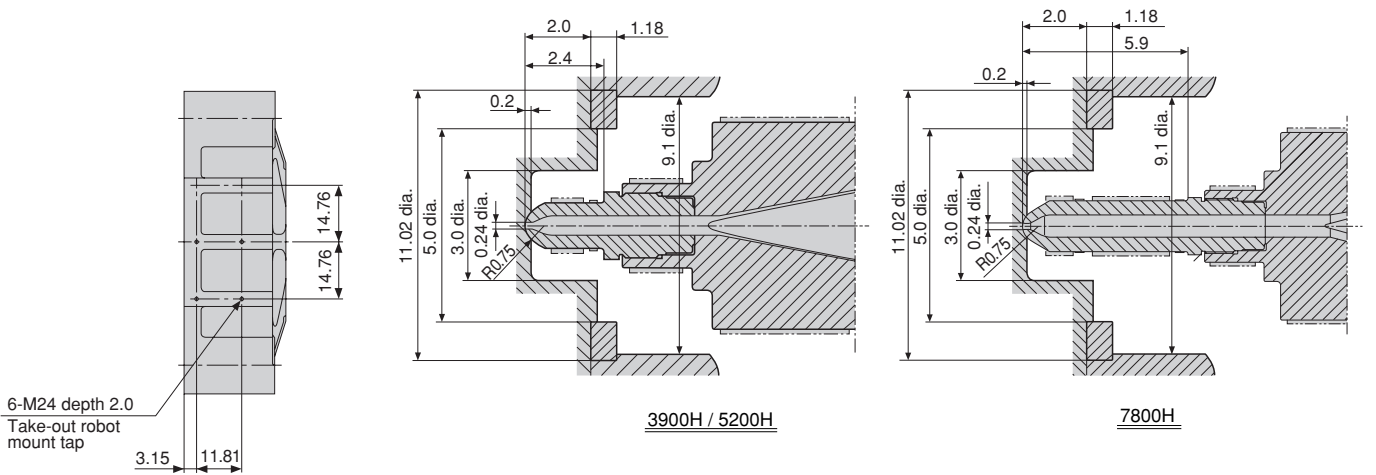
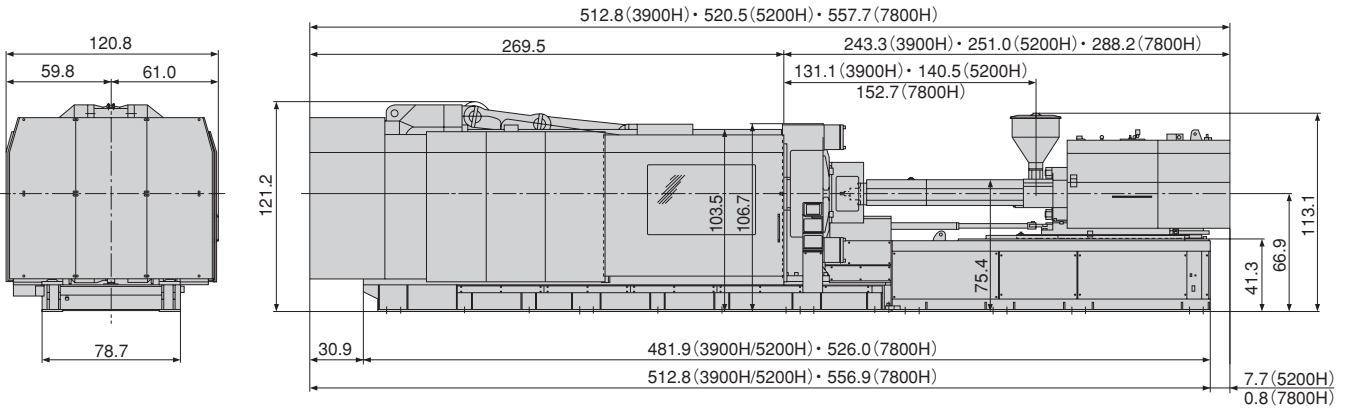

Upper surface of stationary platen

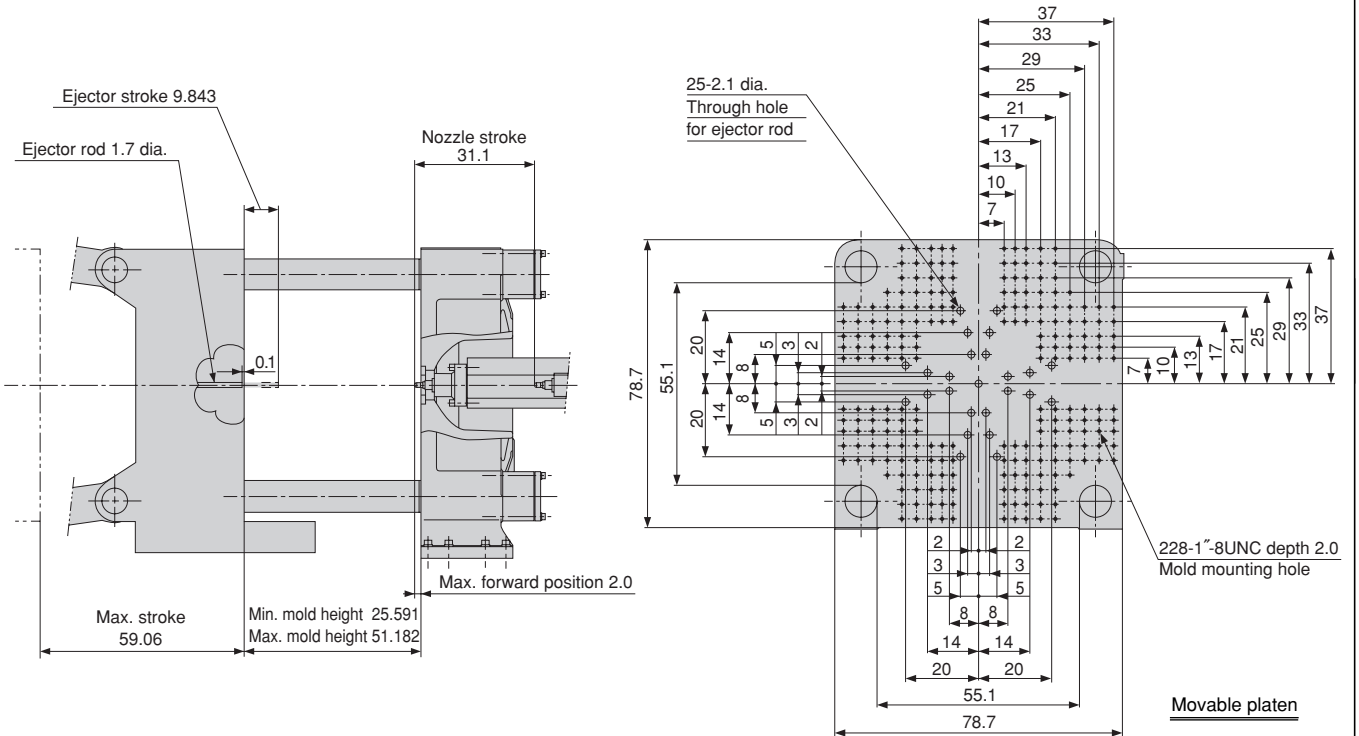

Movable platen